

# Data Sheet

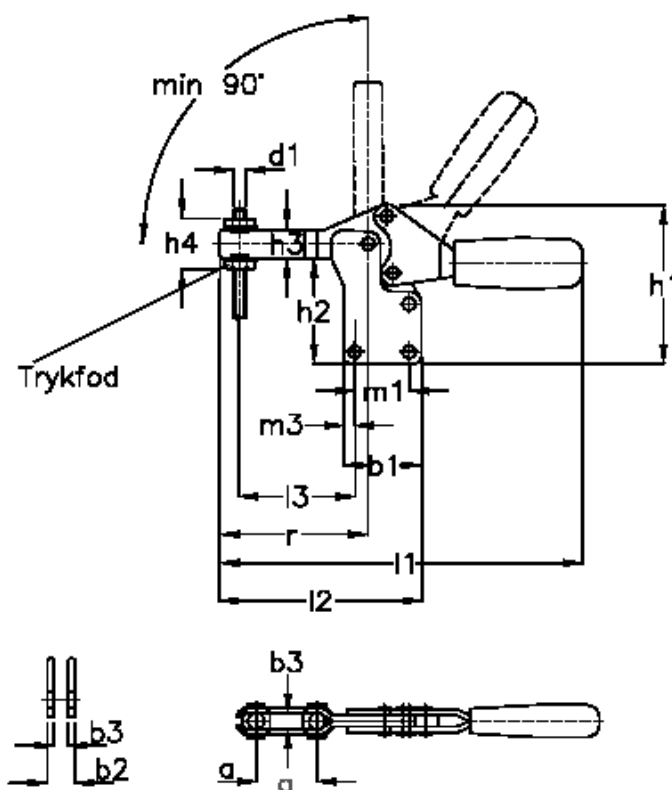

Article number: 201355046A  
 Description: E+G Klee vertical clamp  
 GN 820.1-75-N forked clamping arm

## Measures



a = 20	h2 = 27.5	m2 = 4.5
b1 = 28	h3 = 11	m3 = 7.2
b2 = 8	h4 = 23	r = 43.0
b3 = 4	Holding force N = 900	s = 4
b4 = 5.5	l1 = 118	Size = 70
d1 = M5	l2 = 67	
d2 = 4.5	l3 = 40.0	
h1 = 45.5	m1 = 13.5	